

The Donald W. Reynolds Community Center  
300 W. Evergreen  
Durant, OK 74701

City Of Durant  
300 W. Evergreen  
Durant, OK 74701

LEO A DALY ARCHITECTS  
1000 PINE STREET  
DURANT, OK 74701

5307 E. MOCKINGBIRD LANE, STE. 400  
DURANT, OK 74701  
TEL: 214.526.1144 FAX: 214.526.1411

LIBRARY FEE CONSULTANT  
720 DESIGN  
8704 FERRELL ROAD  
DURANT, OK 74701  
TEL: 214.770.2320

SMIL ENGINEER  
KRG CIVIL ENGINEERS, INC.  
1700 REEB RD., SUITE 325  
DURANT, OK 74701  
TEL: 972.529.7035 FAX: 972.529.7012

STRUCTURAL ENGINEER  
RL GOODSON ENGINEERS  
5445 LOSIERRA, SUITE 300, LB17  
DALLAS, TX 75231  
TEL: 972.353.8888 FAX: 214.739.6354

TLC ENGINEERING  
4131 N. CENTRAL EXPRESSWAY, SUITE 200  
DALLAS, TX 75204 FAX: 214.540.5940  
TEL: 972.353.8888

TECHNOLOGY CONSULTANT  
DATA/COM DESIGN GROUP  
10935 ESTATE LANE, SUITE 385  
DALLAS, TX 75238  
TEL: 214.221-7443

KEY PLAN

REVISIONS table with columns for NO., DESCRIPTION, and DATE.

FILE LOG table with columns for ACTIVITY, BY, DATE, and CHECKED.

DESIGN DEVELOPMENT PACKAGE ISSUED FOR REVIEW AND PRICING ONLY - NOT FOR CONSTRUCTION

Project No. 011-10025-001  
JULY 14, 2009

STANDARD DETAILS SHEET

C6.01

KRG Civil Engineers, Inc.  
1700 REEB RD., SUITE 325  
DURANT, OK 74701  
TEL: 972.529.7035 FAX: 972.529.7012

FIRM REGISTRATION CA 4925  
THIS DOCUMENT IS RELEASED FOR THE PURPOSE OF INTERIM REVIEW UNDER THE AUTHORITY OF KELVIN R. GAVINZ, P.E., LEA, ON 06/24/09. IT IS NOT TO BE USED FOR CONSTRUCTION, PERMITS OR PERMIT REVISIONS.

05 NOT USED NOT TO SCALE

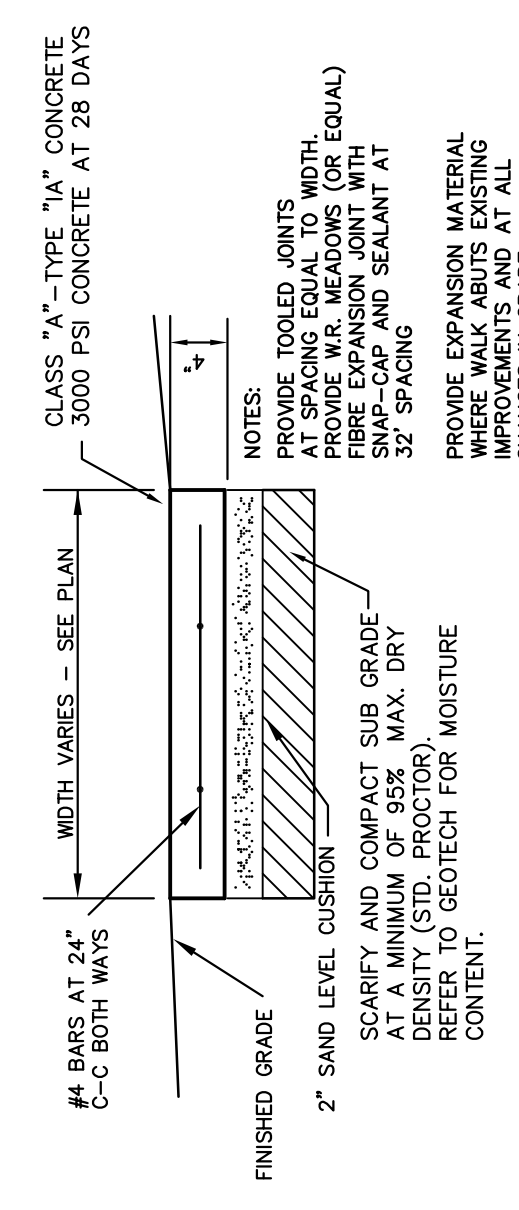

10 CONCRETE SIDEWALK NOT TO SCALE

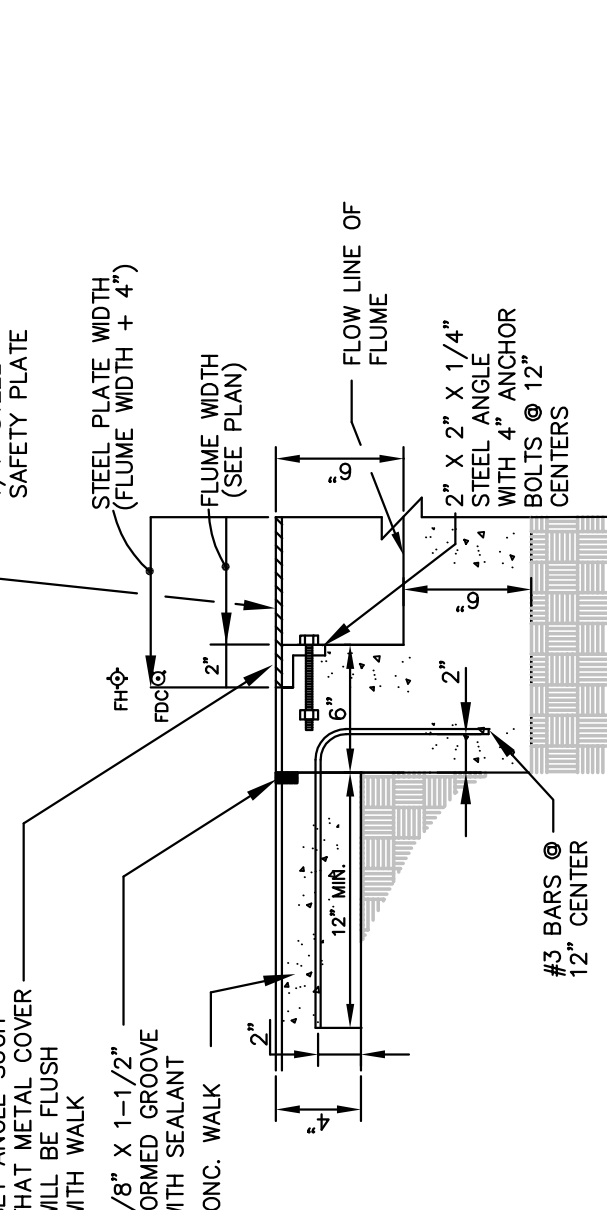

15 FLUME COVER DETAIL NOT TO SCALE

04 NOT USED NOT TO SCALE

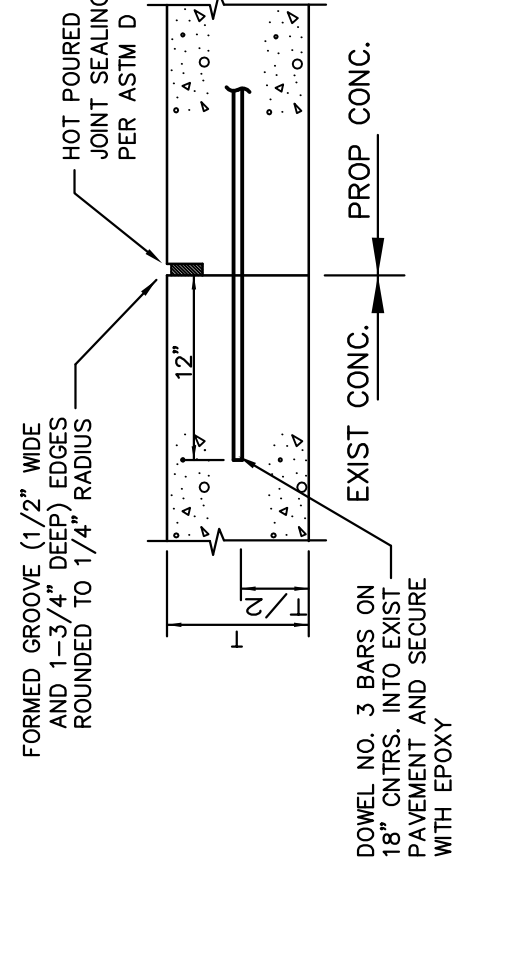

09 PAVEMENT CONNECTION NOT TO SCALE

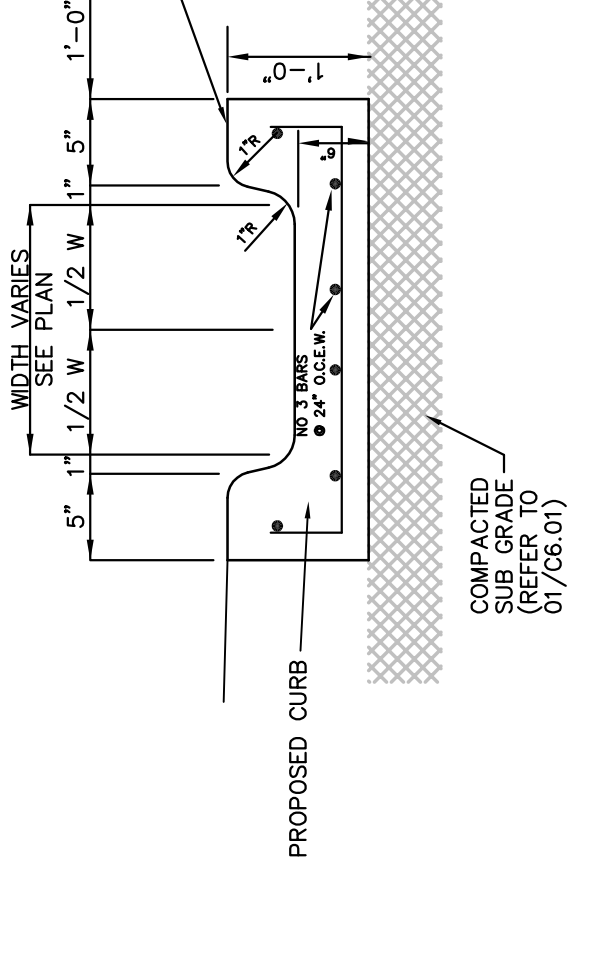

14 FLUME DETAIL NOT TO SCALE

03 CONCRETE CURB NOT TO SCALE

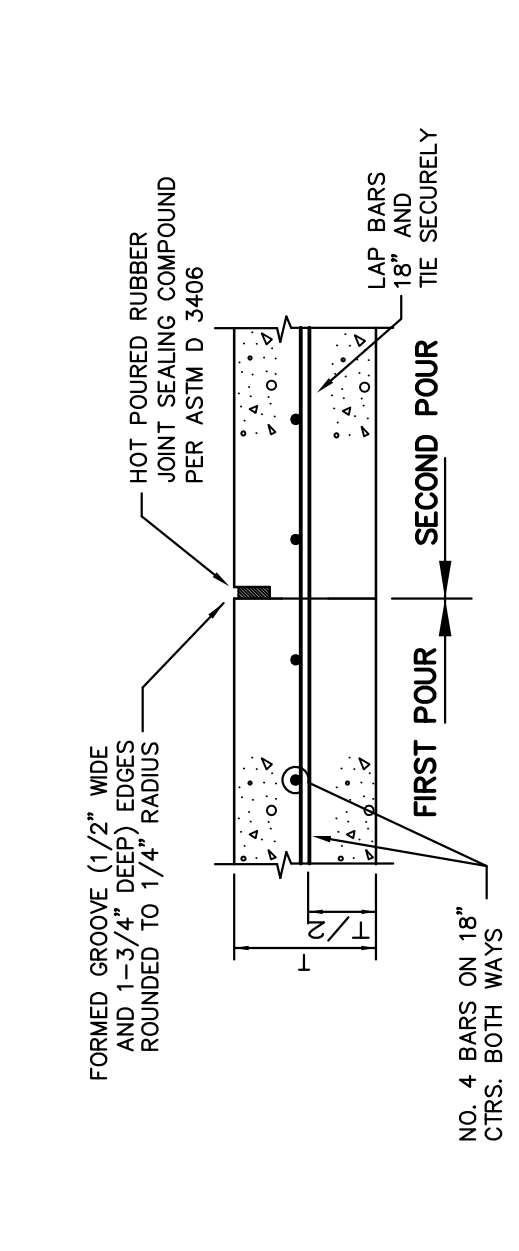

08 CONSTRUCTION JOINT NOT TO SCALE

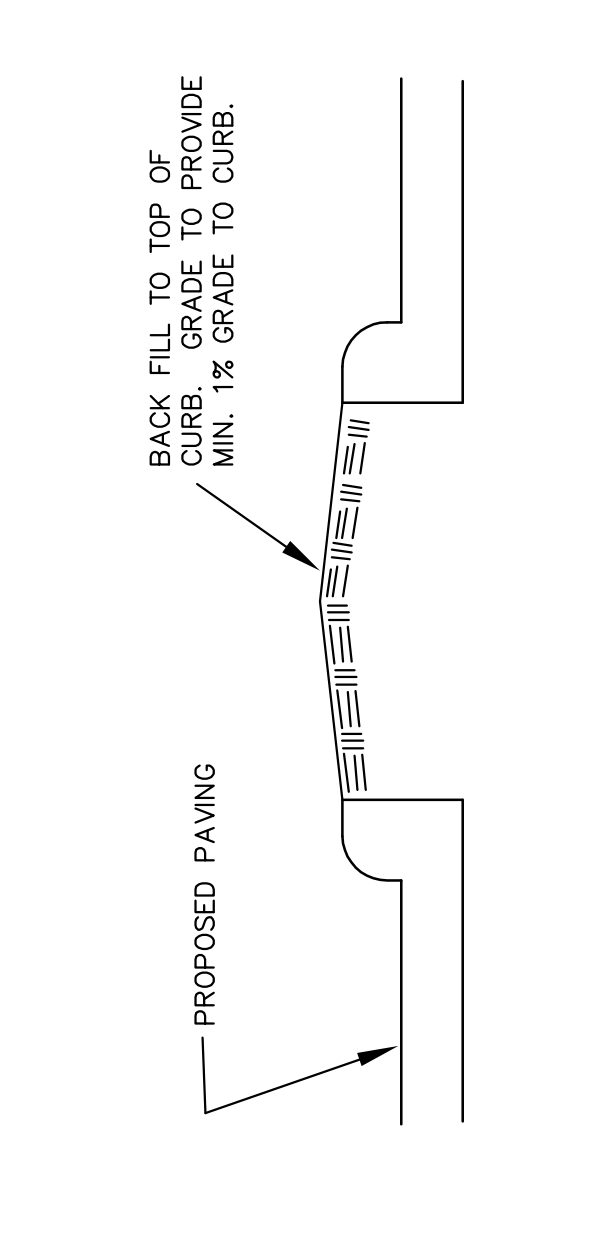

13 ISLAND BACK FILL NOT TO SCALE

02 NOT USED NOT TO SCALE

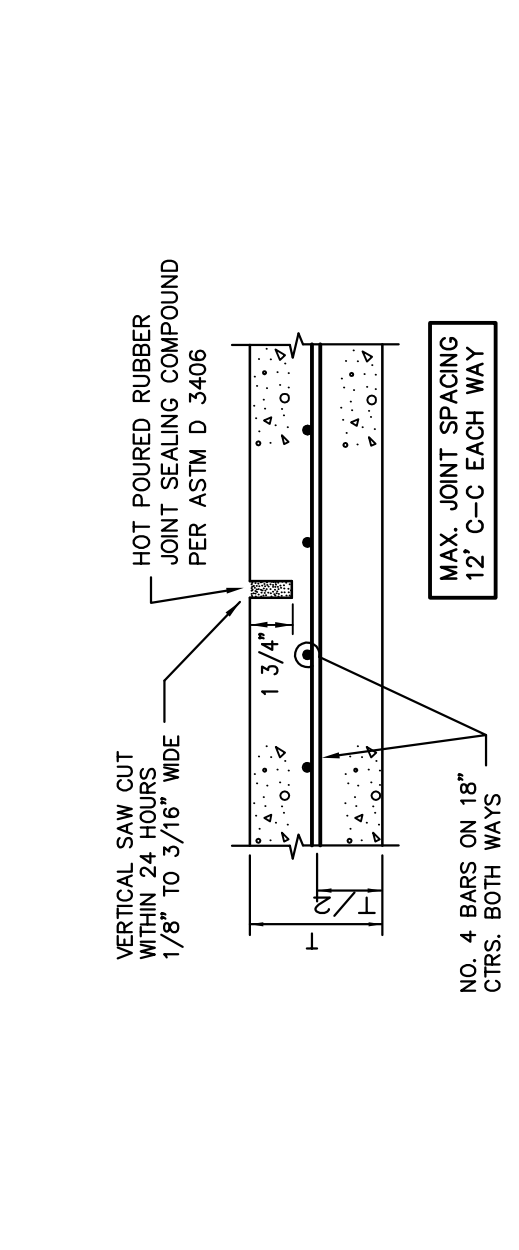

07 SAWED DUMMY JOINT NOT TO SCALE

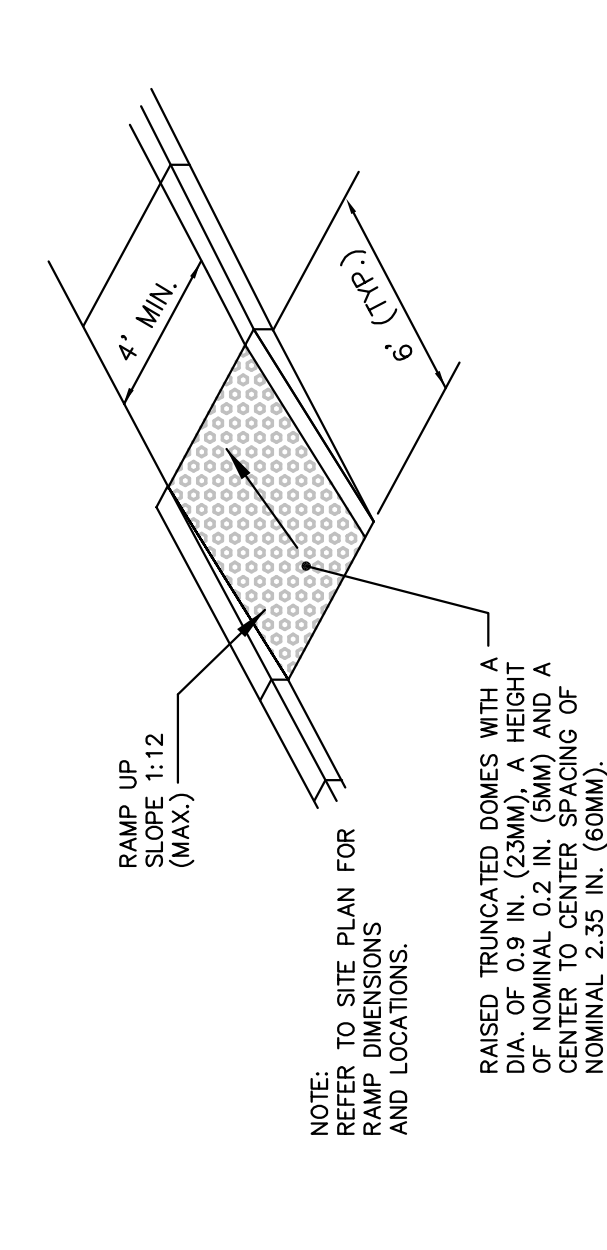

12 BARRIER FREE RAMP NOT TO SCALE

01 PAVEMENT SECTION NOT TO SCALE

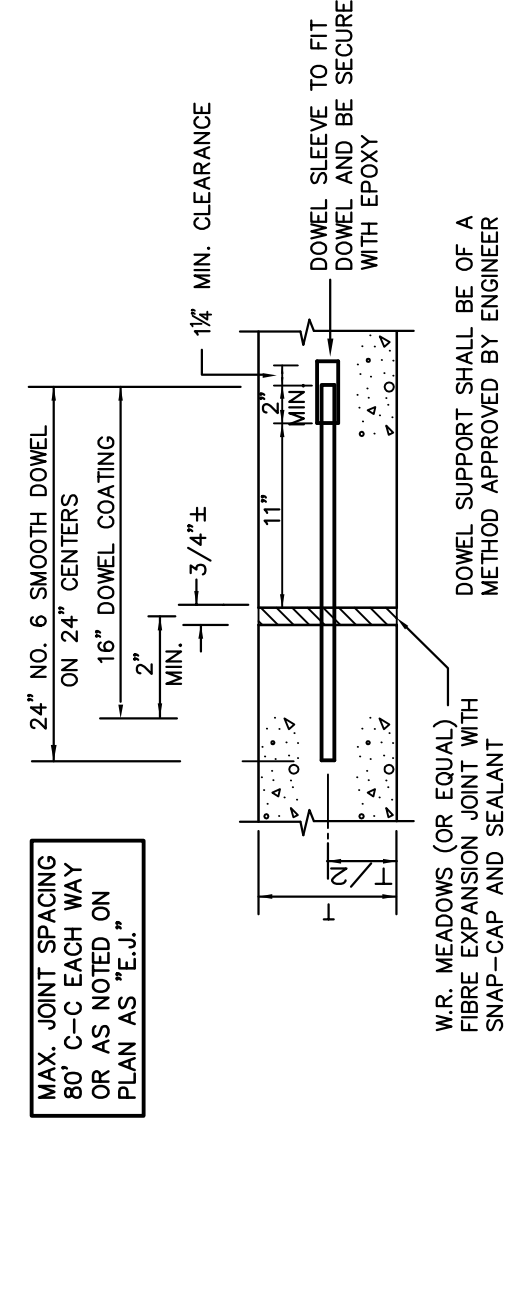

06 EXPANSION JOINT NOT TO SCALE

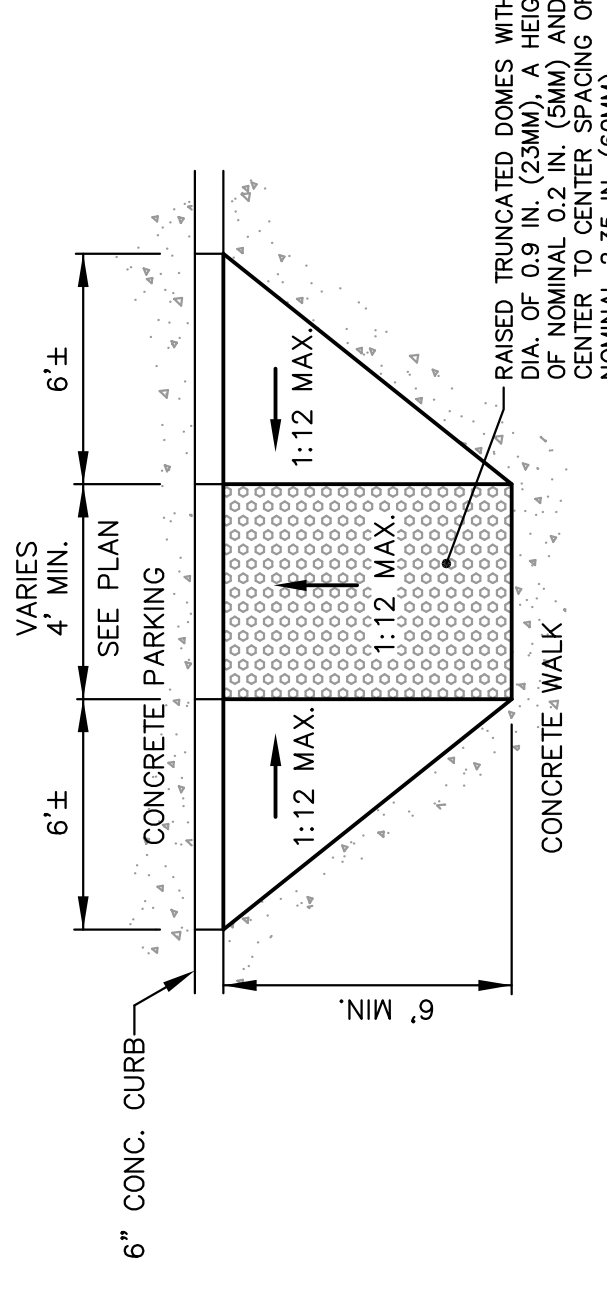

11 BARRIER FREE RAMP PRIVATE USE ONLY NOT TO SCALE

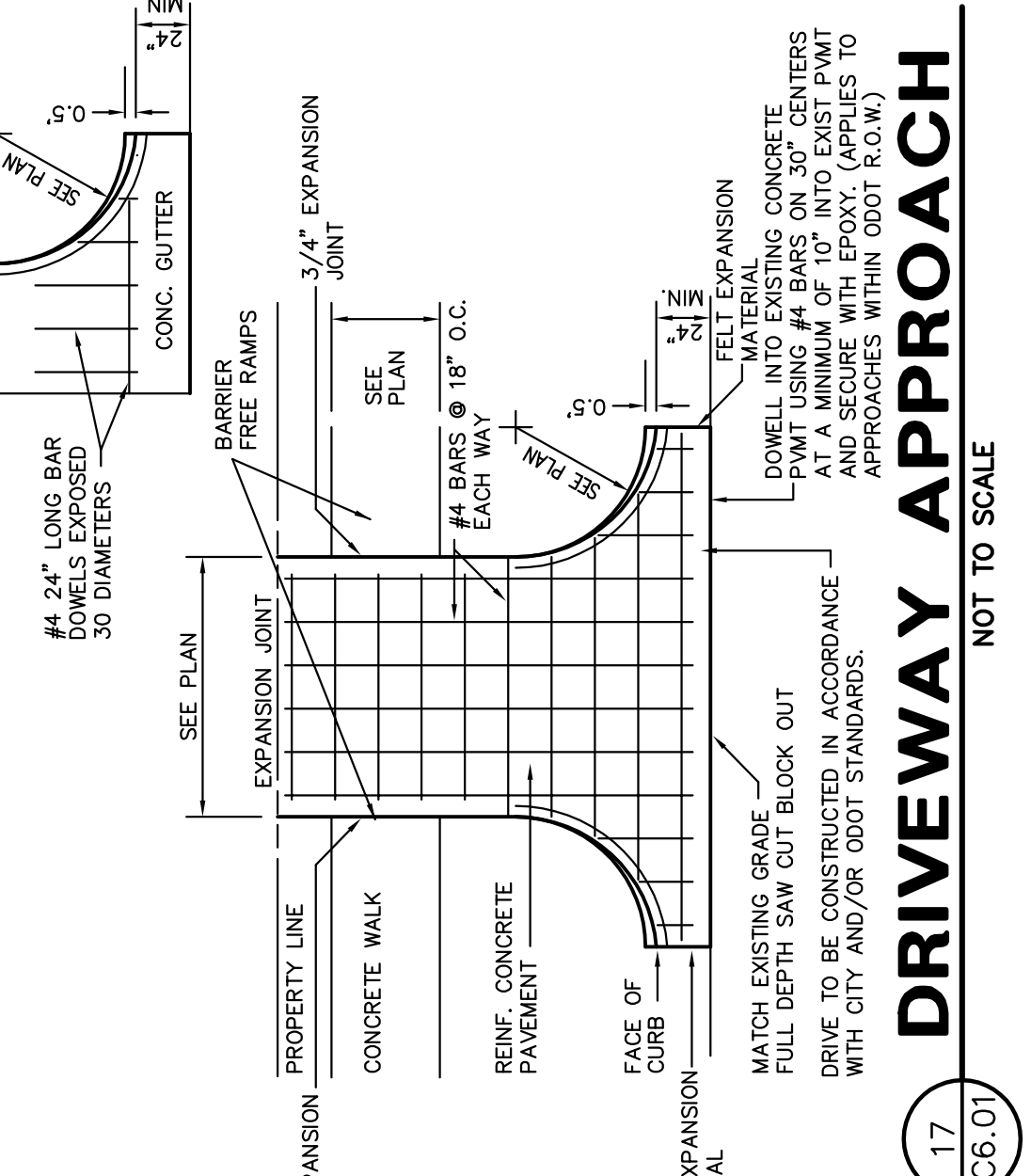

17 DRIVEWAY APPROACH NOT TO SCALE

20 NOT USED NOT TO SCALE



19 FIRE LANE STRIPING NOT TO SCALE



16 HANDICAPPED PARKING NOT TO SCALE



21 DRIVE CROSS SECTION NOT TO SCALE